

Item No. \_\_\_\_\_  
 Project \_\_\_\_\_  
 Quantity \_\_\_\_\_

**LRC7 Electric Rethermalizing Oven**

**Model: LRC7**



**LRC7 Rethermalizer**  
(shown with LCR7 Rotisserie)

**Construction Features:**

- Stainless steel interior and exterior
- Full view double pane loading door with low-E reflective coating on windows and hinged inner pane for easy cleaning
- Bright interior lighting
- 6 each 21"x 26-1/2" removeable racks

**Performance Features:**

- Fast acting heater elements
- Interior fans to thoroughly circulate convection air

**Control Features:**

- Temperature Range: 145-480 deg F
- Simple and intuitive layout
- Large displays for Time and Temperature
- Alarm to alert user when actual temperature reaches set point
- Temperature displayable in deg F or deg C
- Set point retained in memory, reappears on subsequent startups
- 99 hour 59 minute timer

**Options and Assessories:**

- 208V 3ph 60Hz (standard) or optional 208V 1ph, 240 1ph or 240V 3ph
- Stackable with LCR7 Rotisserie or another LRC7 Rethermalizer
- Casters (standard) or optional 4" countertop legs, legs, 6" floor legs or LST7 Stand
- Accessory: MSR7 Mobile Skewer Rack
- Accessory: Chain Restraint Kit

**Short Bid Specification:**

Rethermalizing Cabinet shall be an **LBC model LRC7** electrically heated oven with digital thermostatic control. Control shall have large LED displays for Temp and Time. Oven shall have 6 each 21.0" x 26.5" removable stainless steel racks with stainless steel side supports to allow vertical positioning. Loading door shall have tempered full view glass with hinged inner pane for cleaning. Complete rethermalizing cabinet shall also include all features listed and options checked.

**Standard Product Warranty:**

1 year parts and labor (contiguous US, Alaska, Hawaii & Canada)



Meets UL197 and NSF4 Standards

Sheet Number LRC7 E (Rev D 10/16)

**Installation Requirement:**

Each unit ships separately. Stacking may be required.

**Options and Accessories** (check as required):

- 208V 1ph 60Hz
- 240V 1ph 60Hz
- 240V 3ph 60Hz
- 4" countertop legs
- 6" floor legs
- LRC7 Rethermalizer
- LCR7 7-Spit Rotisserie
- LST7 Stand
- MSR7 Mobile Skewer Rack

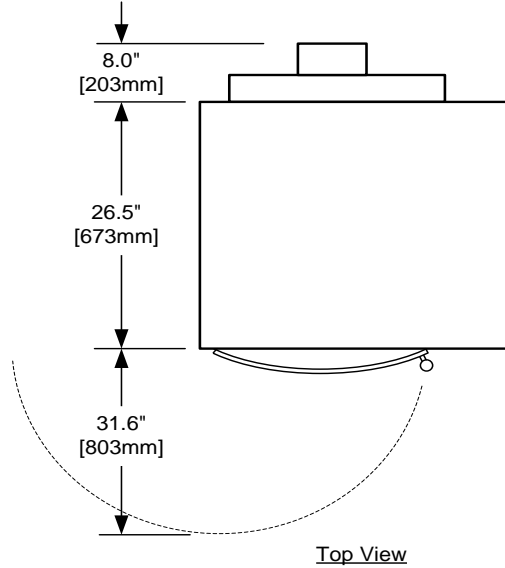
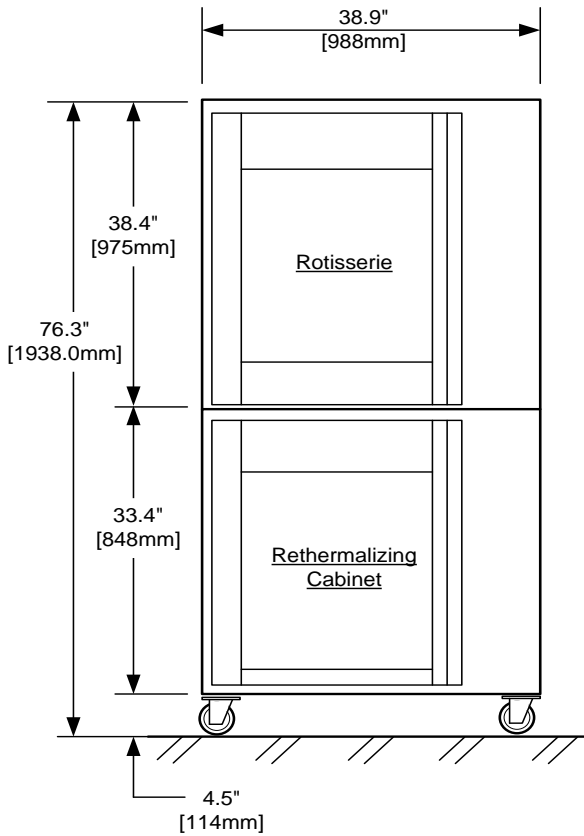

Model	Voltage	kW	Min Circuit Ampacity		Max Breaker Size	
			1 Phase	3 Phase	1 Phase	3 Phase
LCR7 Rotisserie	208VAC	8.0	55	N/A	60	N/A
	240VAC	8.0	50	N/A	60	N/A
	208VAC	9.0	N/A	40	N/A	60
	240VAC	9.0	N/A	35	N/A	60
LRC7 Rethermalizer	208VAC	8.0	55	N/A	60	N/A
	240VAC	8.0	50	N/A	60	N/A
	208VAC	9.0	N/A	40	N/A	60
	240VAC	9.0	N/A	35	N/A	60

Model	Actual Weight	Ship Weight	Freight Class
LCR7 Rotisserie	460 lbs	610 lbs	85
LRC7 Rethermalizer	460 lbs	610 lbs	85