

Electric "Mini" Rotating Rack Oven with Proofer Base

Model LMO-E-P



LMO-E (shown with 8-pan rack and LMO-P Proofer Base)



Oven meets UL 197 and NSF 4 Standards
Proofer meets UL 197 and NSF 2 Standards

Short Bid Specification:

Oven shall be an **LBC Mini Rotating Rack Electric Oven with Proofer Base, model number LMO-EX-Y-P** (for X, enter 6, 8 or 10 for Rack Choice; for Y, enter 208, 240 or 480 for Voltage Choice). **Oven** shall have an internal steam system consisting of 150 lbs of thermal mass and a stainless steel water drop system to dispense water to the mass. The oven shall be electrically heated with tubular heaters. **Proofer Base** shall have double doors with the controller located in right door, 12-pan capacity, a quick-response air-wash heat and humidity system, 2 ea heavy-duty locking swivel casters at the front and a 6' cord with NEMA 5-15 plug.

Standard Product Warranty:

One Year Parts and Labor (Contiguous US, Alaska, Hawaii & Canada)

Rack Capacities:

Usage	LMO-E6 (6-Pan Rack)	LMO-E8 (8-Pan Rack)	LMO-E10 (10-Pan Rack)
18" x 26" Sheet Pans	6	8	10
18" x 13" 1/2-Size Pans	12	16	20
3-Strap Pan Bread	12	N/A	N/A
Baguettes, 8 oz	30	40	N/A
Cookies, 2 oz	12 dozen	16 dozen	20 dozen

Construction Features:

- Stainless steel interior and exterior
- Heavy-duty swivel casters; front pair locking
- Oven:
 - Low pressure water injection steam system with 150 lbs of thermal mass for maximum steam
 - Double doors open simultaneously and latch to prevent accidental opening during operation
 - Inner glass panes hinged for easy cleaning
 - Full perimeter silicone door seal
- Proofer Base:
 - 12 ea rack slides
 - Quick responding air-wash heat and humidity system with non-submerged tubular heaters
 - Pre-installed 6' cord with NEMA 5-5R plug

Performance Features:

- Oven:
 - 1 gallon of water per 20 sec steam cycle
 - Programmable vent
 - Safety limited torque-drive rotation system
 - Low noise air circulation system
 - Brightly lit interior
- Proofer Base:
 - Capacity: 12 ea 18" x 26" sheet pans
 - Temp Range: 70 - 120 deg F
 - Humidity Range: 50 - 99%

Control Features:

- Large easy-to-read LED displays
- Oven:
 - Two control modes with programmable features
 - > Single-step cooking mode:
 - » 40 programmable recipes with 6 quick select buttons
 - > 6-step cooking mode:
 - » 30 programmable recipes
 - Programmable features: Steam, Vent, Blower Delay and Pulse Air
 - Selectable Automatic Temperature Setback
- Proofer Base:
 - PID feedback design for rapid and accurate response with no temperature overshoot

Options and Accessories:

- Rack Options: **6** (6-Pan, 5-1/2" spacing), **8** (8-Pan, 4" spacing) or **10** (10-Pan, 3-1/4" spacing)
- Voltage Options: 208V, 240V, or 480V
- Accessory: Water Connection Kit
- Accessory: Water Filtration Assembly

Electric “Mini” Rotating Rack Oven with Proofer Base

Model LMO-E-P

Installation Requirements:

- Factory authorized start-up required
- Ships in two pieces. Will fit through a 34” opening with some disassembly
- Clearance to combustibles: 0” Sides and Back, 18” Top
- Check local codes to determine if oven requires a hood

Build Model Number with Options:

Rack Choice

- 6** = 6-Pan Rack
(5-1/2” spacing)
- 8** = 8-Pan Rack
(4” spacing)
- 10** = 10-Pan Rack
(3-1/4” spacing)

Voltage Choice

- 208** = 208V
- 240** = 240V
- 480** = 480V

LMO - E - - **P**

Accessories:

- 74000-51** Water Connection Kit
- 72610-48** Water Filtration Assembly

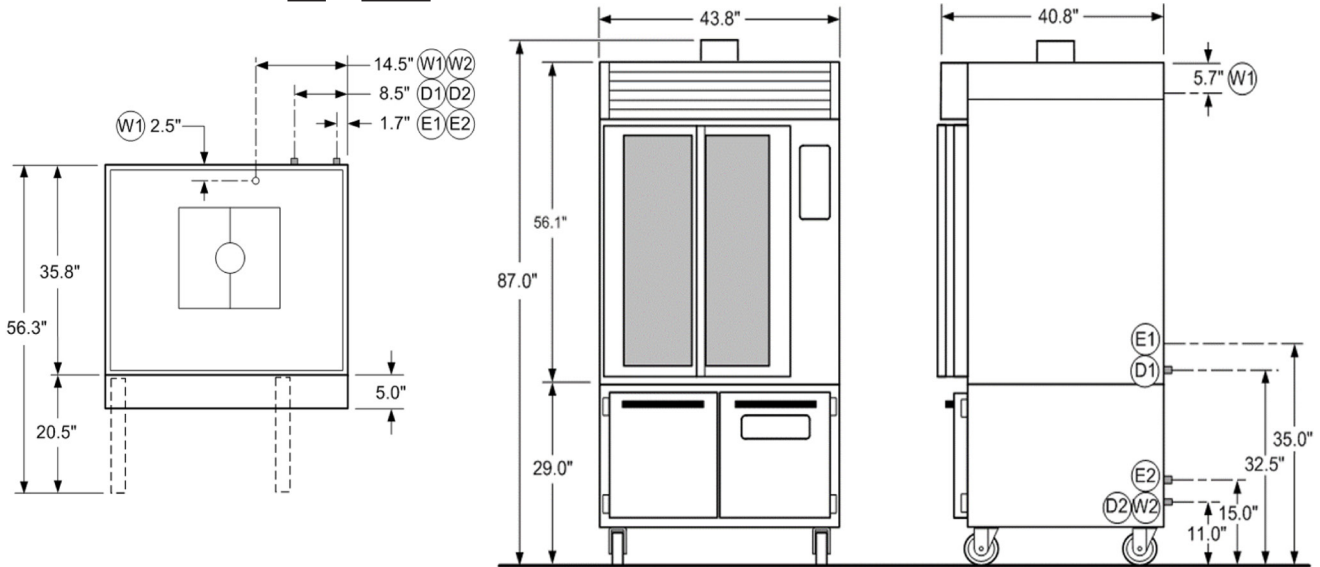

Water Quality Requirements:

pH: 7.0-8.5
Total Hardness < 50 ppm
Chlorides < 50 ppm
Total Chlorine < 0.5 ppm
Iron < 0.3 ppm

Utility Requirements:

Appliance	(E) Electrical		Amps			MCA	MOP	(W) Water	(D) Drain
			L1	L2	L3				
Oven	Control Circuit *	120VAC, 1ph, 60Hz, dedicated	7	N/A	N/A	20	20	1/2" NPT, cold, 3 gph @ 45psi	Route to air gap drain
	208V Heater Circuit *	208VAC, 3ph, 60Hz	39	26	39	50	60		
	240V Heater Circuit (option) *	240VAC, 3ph, 60Hz	30	30	30	40	60		
	480V Heater Circuit (option) *	480VAC, 3ph, 60Hz	15	15	15	20	30		
Proofer Base	120V Control/Heater Circuit	120VAC, 1ph, 60Hz, dedicated	15	N/A	N/A	15	20	3/8" NPT	

* Oven Requires two electrical connections — one for Control Circuit and one for Heater Circuit

Shipping Information:

Appliance	Ship Weight	Freight Class
Oven	1,165 lbs	77.5
Proofer Base	425 lbs	85