

Gas "Mini" Rotating Rack Oven with Proofer Base

Model LMO-G-P



LMO-G (shown with 8-pan rack and LMO-P Proofer Base)



Oven meets ANSI Z83.11 and NSF 4 Standards
Proofer meets UL 197 and NSF 2 Standards

Short Bid Specification:

Oven shall be an **LBC Mini Rotating Rack Gas Oven with Proofer Base, model number LMO-GX-Y-P** (for X, enter 6, 8 or 10 for Rack Choice; for Y, enter N or LP for Gas Choice). **Oven** shall operate on natural gas or propane gas and have an internal steam system consisting of 150 lbs of thermal mass and a stainless steel water drop system to dispense water to the mass. The oven shall be indirectly fired at a rate of 90 kBTU/hr with an in-shot burner system and shall have a heat exchanger with exchange tubes positioned vertically to utilize natural draft for combustion air intake and exhaust. Oven requires installation under a hood. **Proofer Base** shall have double doors with the controller located in right door, 12-pan capacity, a quick-response air-wash heat and humidity system, 2 ea heavy-duty locking swivel casters at the front and a 6' cord with NEMA 5-15 plug.

Standard Product Warranty:

One Year Parts and Labor (Contiguous US, Alaska, Hawaii & Canada)

Rack Capacities:

| Usage | LMO-G6 (6-Pan Rack) | LMO-G8 (8-Pan Rack) | LMO-G10 (10-Pan Rack) |
|-------------------------|------------------------|------------------------|--------------------------|
| 18" x 26" Sheet Pans | 6 | 8 | 10 |
| 18" x 13" 1/2-Size Pans | 12 | 16 | 20 |
| 3-Strap Pan Bread | 12 | N/A | N/A |
| Baguettes, 8 oz | 30 | 40 | N/A |
| Cookies, 2 oz | 12 dozen | 16 dozen | 20 dozen |

Construction Features:

- Stainless steel interior and exterior
- Heavy-duty swivel casters; front pair locking
- Oven:
 - Vertical-tube heat exchanger
 - Low pressure water injection steam system with 150 lbs of thermal mass for maximum steam
 - Field connection for hood proving switch *
 - Double doors open simultaneously and latch to prevent accidental opening during operation
 - Inner glass panes hinged for easy cleaning
 - Full perimeter silicone door seal
- Proofer Base:
 - 12 ea rack slides
 - Quick responding air-wash heat and humidity system with non-submerged tubular heaters
 - Pre-installed 6' cord with NEMA 5-5R plug

Performance Features:

- Oven:
 - 90 kBTU/hr heat input
 - 1 gallon of water per 20 sec steam cycle
 - Programmable vent
 - Safety limited torque-drive rotation system
 - Low noise air circulation system
 - Brightly lit interior
- Proofer Base:
 - Capacity: 12 ea 18" x 26" sheet pans
 - Temp Range: 70 - 120 deg F
 - Humidity Range: 50 - 99%

Control Features:

- Large easy-to-read LED displays
- Oven:
 - Two control modes with programmable features
 - > Single-step cooking mode:
 - » 40 programmable recipes with 6 quick select buttons
 - > 6-step cooking mode:
 - » 30 programmable recipes
 - Programmable features: Steam, Vent, Blower Delay and Pulse Air
 - Selectable Automatic Temperature Setback
- Proofer Base:
 - PID feedback design for rapid and accurate response with no temperature overshoot

Options and Accessories:

- Rack Options: **6** (6-Pan, 5-1/2" spacing), **8** (8-Pan, 4" spacing) or **10** (10-Pan, 3-1/4" spacing)
- Gas Options: Natural or Propane Gas
- Accessory: Water Connection Kit
- Accessory: Gas Connection Kit
- Accessory: Water Filtration Assembly

* The Commonwealth of Massachusetts requires that gas flow must be prohibited when the exhaust hood is not operational.

Gas "Mini" Rotating Rack Oven with Proofer Base

Model LMO-G-P

Installation Requirements:

- Factory authorized start-up required
- Ships in two pieces. Will fit through a 34" opening with some disassembly
- Clearance to combustibles: 0" Sides and Back, 18" Top
- Oven must be installed under an approved Type I or II hood, provided there is 18" clearance from oven vent collar to hood filters

Note: The Commonwealth of Massachusetts requires that gas flow must be prohibited when the exhaust hood is not operational. Installation Manual contains all connection information.

Build Model Number with Options:

Rack Choice

- 6 = 6-Pan Rack (5-1/2" spacing)
- 8 = 8-Pan Rack (4" spacing)
- 10 = 10-Pan Rack (3-1/4" spacing)

Gas Choice

- N = Natural Gas
- LP = Propane

Accessories:

- 74000-51 Water Connection Kit
- 70302-09 Gas Connection Kit
- 72610-48 Water Filtration Assembly

LMO - G - - P

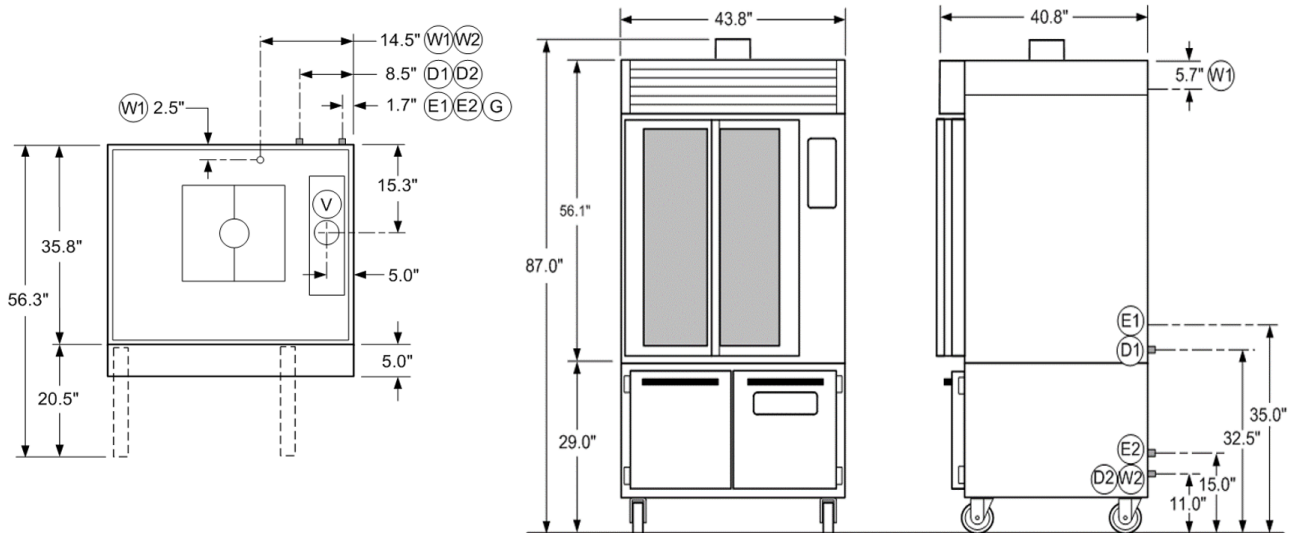

Water Quality Requirements:

| |
|--------------------------|
| pH: 7.0-8.5 |
| Total Hardness < 50 ppm |
| Chlorides < 50 ppm |
| Total Chlorine < 0.5 ppm |
| Iron < 0.3 ppm |

Utility Requirements:

| Appliance | (E) Electrical | (G) Gas | (V) Vent | (W) Water | (D) Drain |
|--------------|--|---|--|-------------------------------|------------------------|
| Oven | 120VAC, 15A, 60Hz dedicated circuit, NEMA 5-15 | 1/2" NPT supply, 90 kBTU/hr, 5-14" w.c. at all times (N) or 11-14" w.c. at all times (LP) | 6" round vent collar (vent not included) † | 1/2" NPT, cold, 3 gph @ 45psi | Route to air gap drain |
| Proofer Base | 120VAC, 15A, 60Hz dedicated circuit | N/A | N/A | 3/8" NPT, cold, 3 gph @ 45psi | |

† Consult your local codes for installation requirements

Shipping Information:

| Appliance | Ship Weight | Freight Class |
|--------------|-------------|---------------|
| Oven | 1,165 lbs | 77.5 |
| Proofer Base | 425 lbs | 85 |