



*Model LMO-P Mini Proofer
shown installed under an LMO Mini Rack Oven*

MODEL LMO-P MINI PROOFER

INSTALLATION, OPERATION & MAINTENANCE MANUAL

RETAIN THIS MANUAL FOR FUTURE REFERENCE

LBC BAKERY EQUIPMENT, INC.

6026 31ST Ave NE

Tulalip, WA 98271, USA

Toll Free: 888-722-5686 (888-RACKOVN)

Email: sales@lcbakery.com

www.lcbakery.com

READ FIRST

FOR YOUR SAFETY

THIS MANUAL HAS BEEN PREPARED FOR PERSONNEL QUALIFIED TO INSTALL ELECTRIC EQUIPMENT, WHO SHOULD PERFORM THE INITIAL FIELD START-UP AND ADJUSTMENTS OF THE EQUIPMENT COVERED BY THIS MANUAL

FOR YOUR SAFETY

DO NOT STORE OR USE GASOLINE OR OTHER FLAMMABLE VAPORS OR LIQUIDS IN THE VICINITY OF THIS OR ANY OTHER APPLIANCE

WARNING

**IMPROPER INSTALLATION, ADJUSTMENT, ALTERATION, SERVICE OR MAINTENANCE CAN CAUSE PROPERTY DAMAGE, INJURY OR DEATH.
READ THE INSTALLATION, OPERATING AND MAINTENANCE INSTRUCTIONS THOROUGHLY BEFORE INSTALLING OR SERVICING THIS EQUIPMENT.**

IN THE EVENT OF A POWER FAILURE, DO NOT ATTEMPT TO OPERATE THIS DEVICE.

KEEP AREA AROUND THE OVEN CLEAR OF COMBUSTIBLES.

TABLE of CONTENTS

Conditions of Installation	4
Dimensions and Utility Connection Points	5
Installation and Startup Checklist	6
Manufacturer and Owner Responsibilities	7
Using the Control	8
Electrical Schematic	10
Illustrated Parts Breakdown	11
Warranty	12

CONDITIONS of INSTALLATION

Installation of this equipment must be performed by an authorized service representative. Prior to installation verify that all electrical supplies coincide with the manufacturer's data label located on the right side below the service panel.

Inspection and Un-crating

Upon receipt of shipments, all packages should be inspected, and all visible or concealed damages noted and signed for on the bill of lading. Any other damages should be reported to the carrier within 10 days. Freight damages are the responsibility of the consignee.

All orders for replacement products resulting in freight damages will be processed under LBC's standard terms. Any reimbursement or credit is the responsibility of the freight carrier

Carefully unpack the proofer and place it in a work area as near to the final installation position as possible.

If moving the proofer through a 36" door opening it will be necessary to remove the proofer doors, door latches and door hinges.

Installation Codes

The LMO-P proofer must be installed in accordance with all State and local codes and the National Electrical Code, ANSI/NFPA-70 (latest edition)

DIMENSIONS and UTILITY CONNECT POINTS (Part 1 of 2)

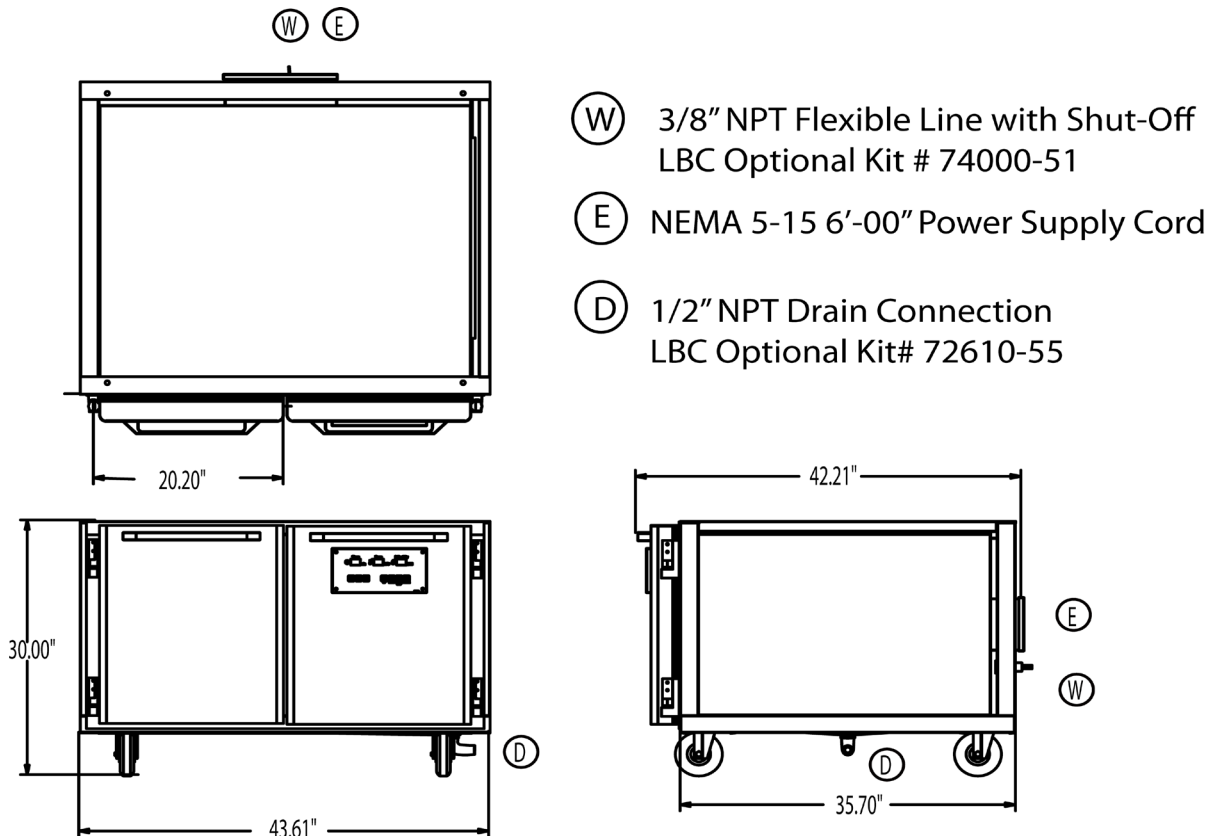

Plumbing Connections

All plumbing connections to the LMO-P proofer must comply with applicable sanitation, safety and plumbing codes.

Water Supply. Proofer water supply should have a hardness of 4 - 6 grains per gallon, a pH of 6.5 - 8.0 and chlorides of less than 30 ppm. Water conditions outside of these parameters may void the warranty. Consult your local water company and/or water-conditioning dealer before installing water supply to proofer and/or oven.

Connect cold water supply to 3/8 NPT fitting located at rear of proofer with a 6 ft flexible clear water line. Water supply should have a pressure of 30 - 75 psi when supply valve is opened.

DIMENSIONS and UTILITY CONNECT POINTS (Part 2 of 2)

Drain Connections. Connect 1/2" drain line to 1/2 NPT drain connector located at bottom right side of proofer. Route drain line to a floor drain allowing a minimum 1" air gap between drain line outlet and floor drain.

If the proofer is being used with an oven it is recommended that separate drain and water lines are provided.

Electrical Connections

WARNING

ELECTRICAL AND GROUNDING CONNECTIONS MUST COMPLY WITH THE APPLICABLE PORTIONS OF THE NATIONAL ELECTRICAL CODE AND ALL STATE AND LOCAL CODES.

A 6 ft power supply cord with NEMA 5-15 plug is supplied with proofer. Proofer requires a dedicated 120V, 15A, 60 Hz, single phase supply with ground.

INSTALLATION and STARTUP CHECKLIST

Level appliance	It is important that installation site is level. If needed, shim caster plates with washers to level the appliance.
Connect appliance to water supply	Ensure water supply meets specifications. Damage caused by poor water quality will void warranty.
	Turn supply valve on
	Check for leaks
Connect appliance to power supply	Plug LMO-P cord into a NEMA 5-15 dedicated outlet
Turn control on	Consult control instructions for operation
Validate proofer functions	Allow proofer to cycle on and off several times
	Check temperature output
	Check humidity output
	Inspect drain connections for leaks
Proof product	Ensure drain in not blocked
	If available, test proofing operation with customer's product.
	Adjust heat and humidity settings as needed
Clean appliance	Clean all exterior surfaces with warm soapy water and towel dry
	Polish surfaces using an NSF approved stainless steel polish

MANUFACTURER and OWNER RESPONSIBILITIES

Your LBC Bakery Equipment, Inc. proofer was manufactured to rigid standards. The proofer is ETL listed as a unit and meets applicable safety and sanitation standards.

- A) **The responsibility of the manufacturer** is to supply suitable, comprehensive instructions and recommendations for the operation and maintenance of the subject unit(s).
- B) All operations, maintenance and repair of the subject unit(s) must be performed by properly trained and qualified personnel and all such operations, maintenance and repair must be performed in a diligent manner. It is the **responsibility of the owner/operator** to insure the proper training and diligence of any person with coming into contact with either the subject unit(s) or the output (product, exhaust or otherwise) of the subject unit(s). It is the **responsibility of the owner/operator** to ensure that the subject unit(s) are installed and operated in accordance with OSHA Standard 1910.263.
- C) A regular periodic program of cleaning, inspection and maintenance must be established and comprehensive maintenance records maintained. It is the **sole responsibility of the user** to establish, schedule and enforce the frequency and scope of these programs in keeping with recommended practice and with due consideration given to actual operating conditions. For suggested cleaning schedule visit our Website at www.lcbakery.com. First click on Manuals, then click on Equipment Cleaning under Operation and Programming Manuals. Or call LBC at 888-722-5686 (888-RACKOVN) to have a copy faxed.
- D) The unit(s) must be operated within limits which will not exceed the working limits of any component.

USING the CONTROL (Part 1 of 2)

Proofer Settings

The LBC Model LMO-P controller does not need to be ON to adjust these settings. These settings can be changed at any time. The settings are intended as a guide and will change based on product type and local atmospheric conditions.

1

Setting the Humidity

Press the BLUE Humidity Key and use the Up or Down Arrow keys to set the desired percentage of humidity.
Typical range 85% - 98%

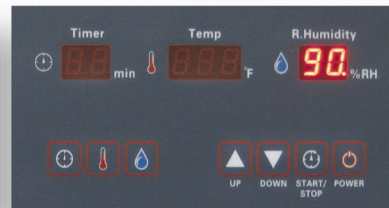

Illustration - 1 Set Humidity

2

Setting the Temperature

Press the RED Temperature Key and use the Up or Down Arrow keys to set the desired temperature in degrees F.
Typical range 95 - 100 Degrees F



Illustration - 2 Set Temperature

3

Setting the Timer

Press the TIME Key and use the Up or Down Arrow keys to set the desired Proofing time in Minutes
Typical range 45 Minutes - 90 Minutes



Illustration - 3 Set Timer

Operations

Press the POWER key to begin heating and producing humidity. The displays will show current temperature and humidity. Allow the appliance to saturate with heat and humidity prior to loading.

As the LRP nears its set-points there may be a rapid "clicking" noise, this is a normal condition.



Illustration - 4 Operations

USING the CONTROL (Part 2 of 2)

User-Level Programming

The following are the default settings, and should not be altered unless instructed by the factory or authorized LBC service agent.

Enter Password;
Press and hold the UP and DOWN Arrow Keys for 3-seconds.
Use the UP or DOWN Arrow keys to enter 08 as shown in illustration 1.



Illustration - 1 Enter Password

Heater Time Alarm;
Press the TIMER Key use the UP or DOWN Arrow keys to change the setting.
Range is 0-99, 0 will disable the alarm.



Illustration - 2 Heater Time Alarm

Temperature Calibration;
Press the TIMER Key use the UP or DOWN Arrow keys to change the settings.
Range is -25 to +25 Degrees F.
This calibration will effect the ability to adjust temperature in the normal operating mode.



Illustration - 3 Temperature Calibration

Humidity Calibration;
Press the TIMER Key use the UP or DOWN Arrow keys to change the settings.
Range is -25% to +25%
This calibration will effect the ability to adjust humidity in the normal operating mode.



Illustration - 4 Humidity Calibration

Temperature Histeris;
Press the TIMER Key use the UP or DOWN Arrow keys to change the settings.
Range is 0-99



Illustration - 5 Temp. Hysteresis

Humidity Histeris;
Press the TIMER Key use the UP or DOWN Arrow keys to change the settings.
Range is 0-99



Illustration - 6 Humidity Hysteresis

Press the TIMER Key to Exit

ELECTRICAL SCHEMATIC

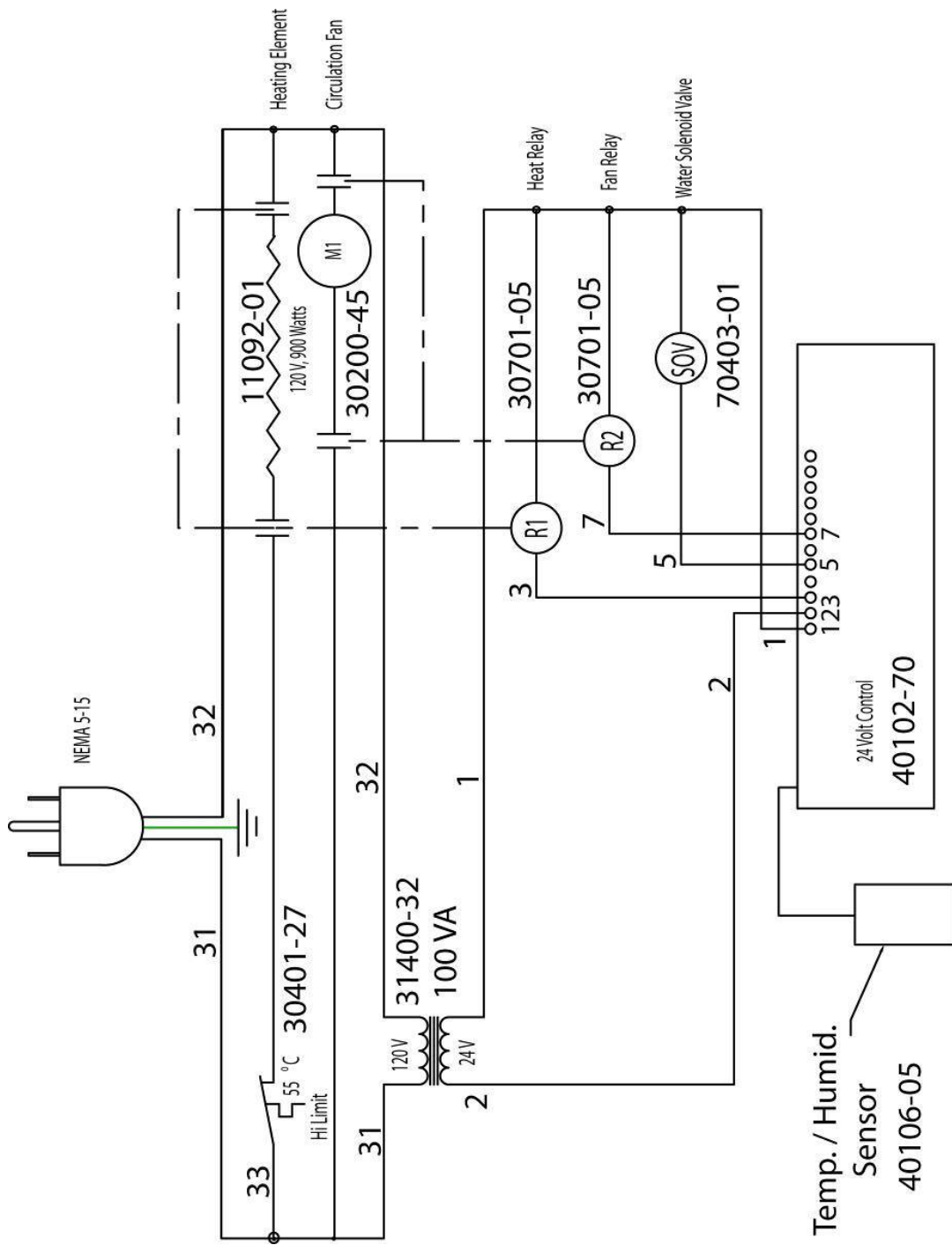

ILLUSTRATED PARTS BREAKDOWN

ITEM NO.	PART NUMBER	DESCRIPTION	QTY.
1	151-756	Frame Assembly-Proofers	1
2	151-767	Heated Plate Assembly	1
3	20101-02	Hex Cap Nut 8mm	16
4	151-422b	Panel, Proofer w/Fan Holes	1
5	151-421	Spacer, Panel-Proofers	4
6	151-768	SPRAY NOZZLE WELD ASSY	1
7	70101-23	ELBOW 1/4 NPT X 8m CC	1
8	31400-32	TRANSFORMER 115V/24V 100VA	1
9	30701-05	CONTACTOR 2 POLE 30A 24 VAC	2
10	30401-27	Hi-Limit Thermostat, 100 C	1
11	151-428	Mount, Hi-Limit Bulb Proofer	1
12	151-755-1	Box Assembly-Proofers	1
13	151-429	Cover, Electrical-Proofers	1
14	151-757-2	Door, RH-Proofers	1
15	151-757-1	Door, LH-Proofers	1
16	40102-71	Control Assembly, Mini Proofer	1
17	30200-45	MOTOR W/ FAN AXIAL 115VAC 70 C	2
18	72801-24-33	Foam Tape, 839mm	4
19	72801-24-42.3	Foam Tape, 575mm	2
20	72801-24-22.68	Foam Tape, 575mm	2
21	70801-11	Grommet, Rubber	3
22	72801-24-37.6	Foam Tape, 955mm	2
23	151-772	Drip Tray, Proofers	1
24	70403-01	Solenoid Valve, 3/8"	1
25	151-427	Mount, Hi Limit-Proofers	1
26	11092-01	Heating Elements	1
27	70101-75	Spray Nozzle	1
28	72602-211-20	Magnetic Door Gaskets	2
29	151-132	Center Door Sweep	2

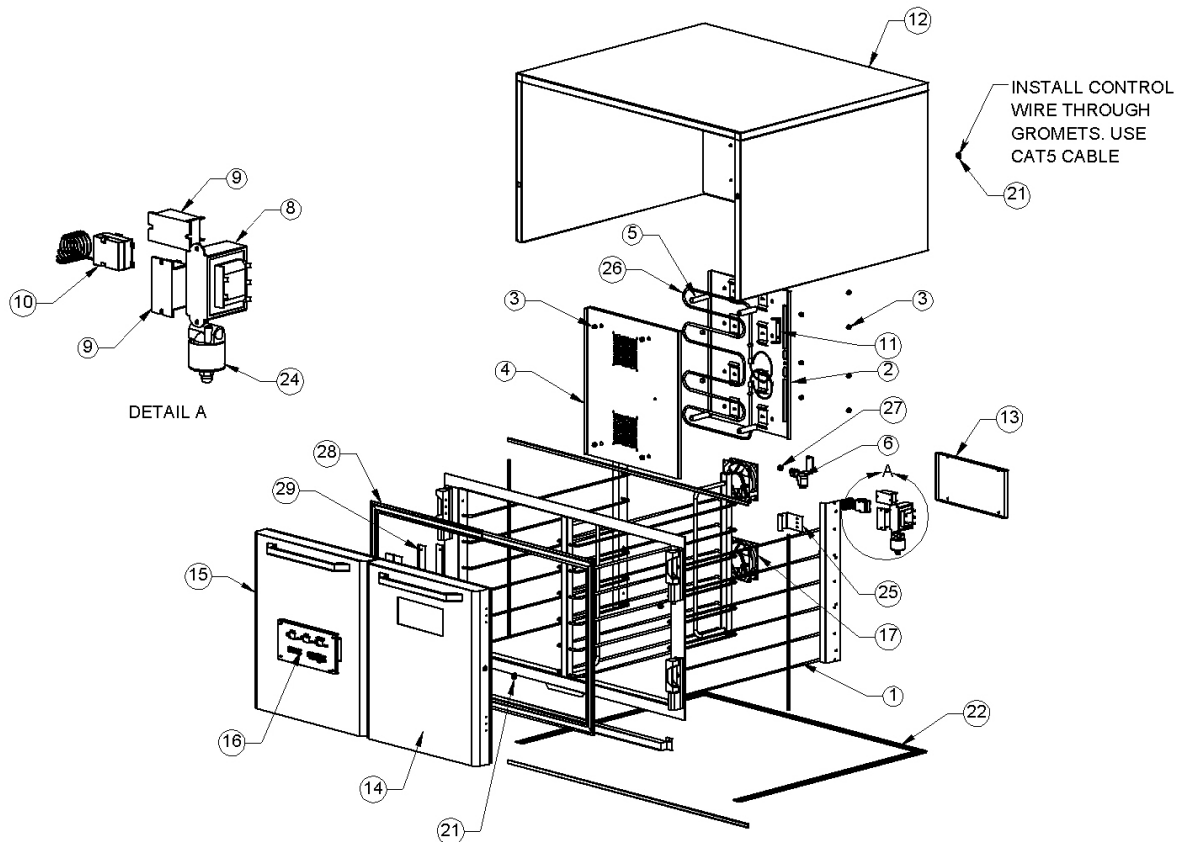

LBC Limited Warranty

LBC Bakery Equipment ("LBC Equipment") has been skillfully manufactured, carefully inspected and packaged to meet rigid standards of excellence. LBC Bakery Equipment Company (LBC) warrants products produced and sold by LBC and its duly authorized agents, against defects in materials and workmanship within the following limitations:

What is provided:

- Limited replacement parts as specified below, including standard ground shipping from LBC or service parts center when required.
- Limited labor for repair as specified below, including authorized service agent's transportation, portal to portal, up to one hundred (100) miles round trip and two (2) hours travel time.
- LBC, or an authorized service representative, will repair or replace, at LBC's sole discretion, any LBC equipment, including but not limited to the listed exclusions.

Coverage Period:

Extending from the date of shipment from LBC or its duly authorized dealer/distributor for the specified period.

- LRO Model Rack Ovens, LRP Model Rack Proofers and LRPR Model Retarder Proofers for a period of one (1) year limited parts and labor.
- Replacement parts shall be warranted for a period of ninety (90) days after installation by an authorized LBC service agent.

Conditions:

- Covered equipment must have been properly installed and according to the requirements of the installation manual and all applicable local codes.
- The equipment shall not have been abused, misused or neglected or used for purposes other than intended by LBC.
- Water connected to the appliance shall have been in compliance with the following requirements:
 - Cold water, 30 to 80 PSI
 - pH between 7 and 7.5
 - Conductivity less than 1/500,000 Ω per inch
 - Total dissolved solids less than 100 ppm
 - Hardness from 6.3 to 8.8 grains per gallon
 - Maximum Salinity and Ion content:

<i>Chlorides:</i>	< 30 ppm
<i>Sulfates:</i>	< 40 ppm
<i>Iron:</i>	< 0.1 ppm
<i>Copper:</i>	< 0.05 ppm
<i>Manganese:</i>	< 0.05 ppm

Conditions (cont):

- It is the responsibility of the purchaser to install and maintain the water supply to the appliance. Failure to provide satisfactory water quality of the appliance in accordance with the operating manual requirements can cause damage to internal components and will VOID the warranty.
- All repair work is to be performed by an LBC authorized service agent.

- Equipment must be at the installation location of the original purchaser/user and shall not have been resold or reclaimed by another party.
- LBC equipment is for commercial use only. If sold as a component of another (OEM) manufacturer's equipment, or if used as a consumer product, such equipment is sold AS IS and without any warranty.
- Conditions of sale of the equipment shall have been met in full.
- The request for repair shall be made within the limited period of the warranty.

Failure to meet the above conditions will void this warranty

Exclusions:

This warranty does not cover the following:

- Routine general maintenance, or periodic adjustment
- Thermostat calibration after the first 30 days of use
- Lamps, Gaskets, Oven Racks and other consumable parts
- Air and gas burner adjustments
- Fuse replacement
- Cleaning and adjusting burners and pilot burners
- Rack oven shutter adjustments
- Repairs adjustments and corrections in the refrigeration portion of retarder/proofers resulting from the improper installation
- Retightening of screws and fasteners
- Failures caused by erratic or inadequate electrical, water, ventilation or gas service
- Unauthorized repairs
- Premature rusting, corrosion, or mineral build up caused by incoming water
- Attached water treatment systems
- Expedited freight on replacement parts other than standard ground shipments
- Ordinary wear and tear
- Use of the equipment for purposes other than those intended including non-commercial use such as residential or domestic
- Appliances installed outside the contiguous U.S., including Alaska and Hawaii, and Canada
- Incidental costs, charges, loss of business and damages as incurred by the user or others as a result of the use or failure of the equipment
- Work and workmanship of the authorized service agent or others in the repair of the equipment
- Other failures that are beyond the reasonable scope of this warranty
- Damage caused during shipment is to be reported to the carrier, is not covered under this warranty, and is the sole responsibility of the purchaser/user
- Natural disasters