



Model LRC7 Rethermalizing Oven

OPERATION, INSTALLATION, SERVICE and PARTS MANUAL

LBC Bakery Equipment, Inc.

6026 31st Ave NE

Tulalip, WA 98271, USA

Phone: 888-RACKOVN (888-722-5686)

Email: parts@lcbakery.com

Website: www.lcbakery.com

Read First

THIS MANUAL MUST BE RETAINED FOR FUTURE REFERENCE. READ, UNDERSTAND AND FOLLOW THE INSTRUCTIONS AND WARNINGS CONTAINED IN THIS MANUAL.

	WARNING DO NOT STORE OR USE GASOLINE OR OTHER FLAMMABLE VAPORS AND LIQUIDS IN THE VICINITY OF THIS OR ANY OTHER APPLIANCE.	
	WARNING IMPROPER INSTALLATION, ADJUSTMENT, SERVICE OR MAINTENANCE CAN CAUSE PROPERTY DAMAGE, INJURY OR DEATH. READ THE INSTALLATION, OPERATING AND MAINTENANCE INSTRUCTIONS THOROUGHLY BEFORE INSTALLING OR SERVICING THIS EQUIPMENT.	
	CAUTION ALWAYS KEEP THE AREA NEAR THE APPLIANCE FREE FROM COMBUSTIBLE MATERIALS.	

This LBC Rethermalizer was manufactured to rigid standards. The appliance has been tested and is listed by Intertek Testing Services (ETL Semko) and meets applicable safety and sanitation standards.

- A) The **responsibility of the manufacturer** is to supply suitable, comprehensive instructions and recommendations for proper operation and maintenance.
- B) All operations, maintenance and repair of this or any LBC Bakery Equipment, Inc. appliance must be performed by properly trained and qualified personnel, and all such operations, maintenance and repair must be performed in a diligent manner. It is the **responsibility of the owner/operator** to ensure proper training and diligence of any person coming into contact with either the subject units or the output (product, fumes or otherwise) of the subject units. It is the **responsibility of the owner/operator** to ensure that the subject units are installed and operated in accordance with OSHA Standard 1910.263.
- C) A regular periodic program of cleaning, inspection and maintenance must be established and comprehensive maintenance records maintained. It is the **sole responsibility of the owner/operator** to establish, schedule and enforce the frequency and scope of these programs in keeping with recommended practice and with due consideration given to actual operating conditions.
- D) The appliance must be operated within limits which will not exceed its working limits. It is the **responsibility of the user** to operate this appliance in accordance with the rules and limits described in this manual and the published product specification sheet, and in accordance with the directions and instructions of the owner/operator of the appliance or employer, and in accordance with applicable federal, state and local laws and ordinances.

Table of Contents

Read First	2
Specifications	4
Configurations	5
Safe Operating Rules	6
Control Overview	8
Maintenance and Cleaning	10
Conditions of Installation	11
Receiving and Unpacking	11
Installation	12
Part List	14
Wiring Schematic	18
Warranty	20

Specifications

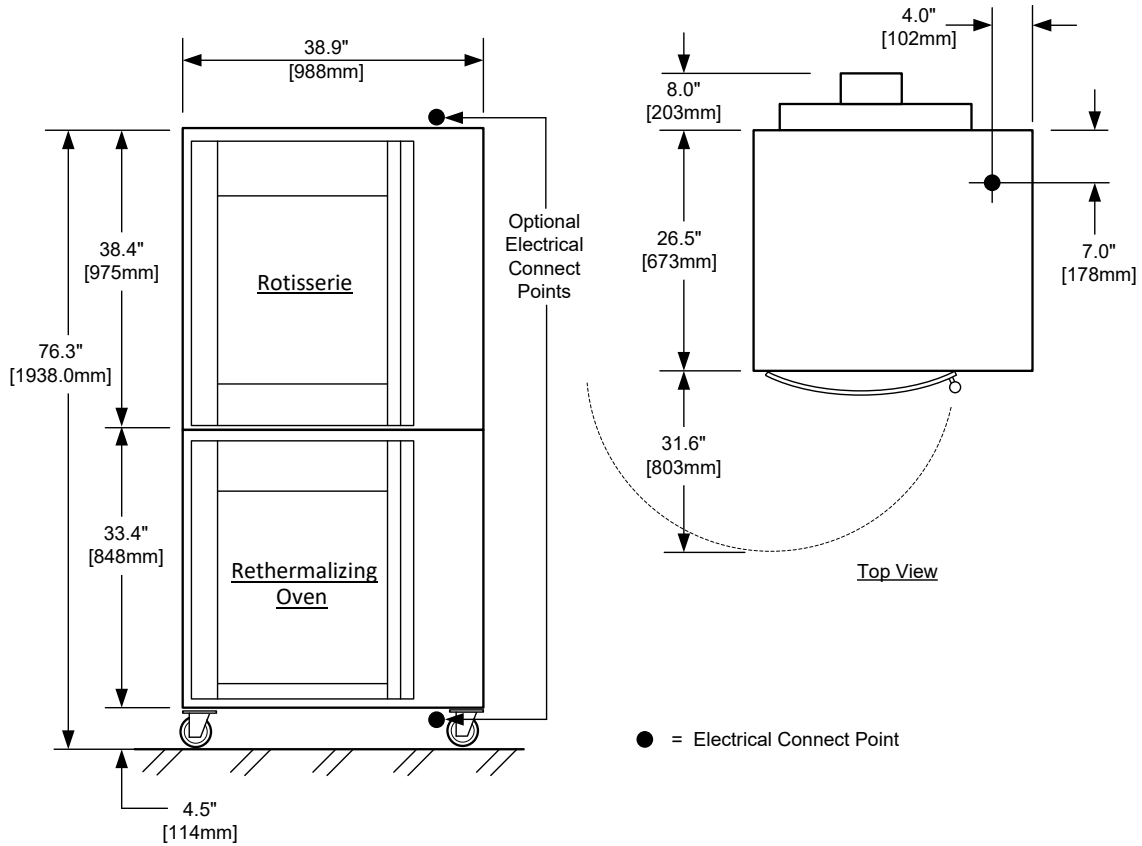

610 lbs

Model	Actual Weight	Ship Weight	Freight Class
LRC7 Rethermalizing Oven	430 lbs	580 lbs	85
LRC7 Chicken Rotisserie (Reference)	460 lbs	610 lbs	85

Model	Voltage	kW	Min Circuit Ampacity		Max Breaker Size	
			1 Phase	3 Phase	1 Phase	3 Phase
LRC7 Rethermalizing Oven	208VAC	8.0	55	N/A	60	N/A
	240VAC	8.0	50	N/A	60	N/A
	208VAC	9.0	N/A	40	N/A	60
	240VAC	9.0	N/A	35	N/A	60
LRC7 Chicken Rotisserie (Reference)	208VAC	8.0	55	N/A	60	N/A
	240VAC	8.0	50	N/A	60	N/A
	208VAC	9.0	N/A	40	N/A	60
	240VAC	9.0	N/A	35	N/A	60

Configurations

Countertop or Floor Mount

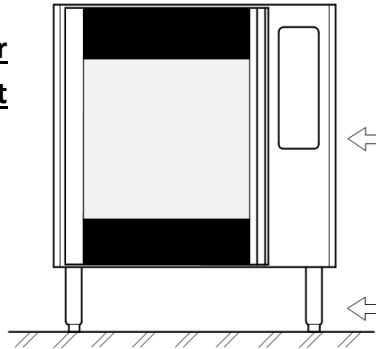

← Rethermalizer

← Countertop: 4.0" Legs

Floor: 6.0" Legs or
4.5" Swivel Casters with Brakes

Stand Mount

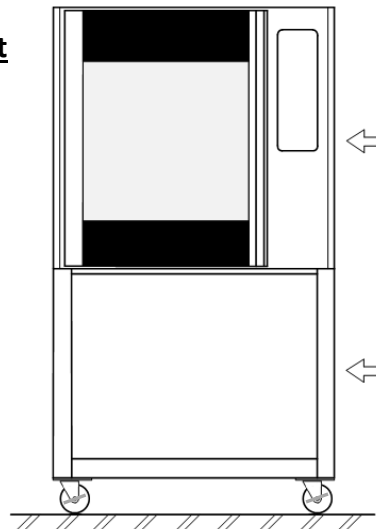

← Rethermalizer

← LST7 Stand

Stacked Appliances

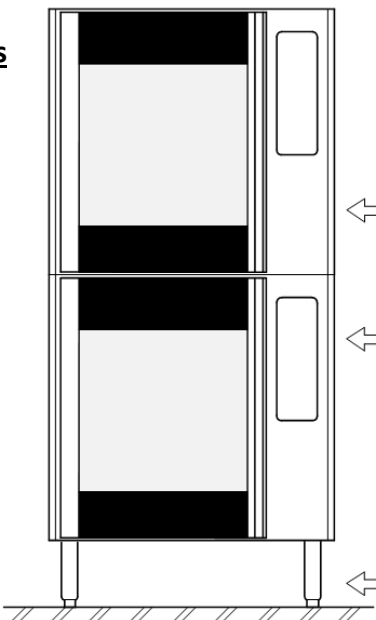

← Combinations:

- 2 ea LRC7 Rethermalizers or
- 1 ea LCR7 Rotisserie + 1 ea LRC7 Rethermalizer

← 6.0" Legs or

4.5" Swivel Casters with Brakes

Safe Operating Rules (Part 1 of 2)

YOU MUST READ AND UNDERSTAND THIS SECTION BEFORE YOU OPERATE THIS APPLIANCE.

Hot Surfaces

- The appliance may be hot. Do not contact hot surfaces in the appliance interior without proper protection. Contact with hot surfaces can cause serious burns, loss of skin and hair and the use of limbs.
- The appliance door may not stay open and may close on its own.
- Avoid contact with hot surfaces when loading or unloading the oven. Use appliance mitts to handle spits, forks or baskets. Contact with hot product can cause you to react suddenly and result in spilling or dropping the product, which can cause physical harm.

Hot Water and Steam

- This appliance produces steam in the process of cooking. When opening the loading door, hot air and steam will be released from the oven interior. Steam is very hot and contact can cause serious burns, loss of skin and hair, loss of the use of limbs and serious injury to eyes and internal organs. Excessive contact with steam can even result in loss of life. Open the loading door slowly and keep your face and hands clear of the opening.
- Steam produced by the appliance can cause the floor to become wet. If this happens, wipe or mop up the water and alert other employees of the hazard.
- Steam and/or hot water may be expelled through the appliance drain. The drain line should be connected to a proper air gap drain during installation to allow excess water to be evacuated from the work area. Steam and water from the drain may be very hot and contact can cause serious burns, loss of skin and hair, loss of the use of limbs and serious injury to eyes and internal organs.
- Use caution to avoid slipping when operating this appliance or when in the area of the appliance. In the event that the drain becomes clogged, continued use of the appliance may result in water spilling onto the floor in the general work area around the appliance. If the drain becomes clogged and water spills on the floor:
 - Stop using the appliance to prevent more water spillage.
 - Mop up and clean up any water on the floor in front of the appliance or in the surrounding work area.
 - Alert other personnel, employees, customers or observers of the hazard.
 - Notify supervisor, servicer or maintenance persons and have the drain unclogged.
- In the normal operation of the appliance, product intended for cooking may spill onto the floor. If this happens:
 - Mop up and clean up any product on the floor in front of the appliance or in the surrounding work area.
 - Alert other personnel, employees, customers or observers of the hazard.

Sharp Edges and Pinch Hazards

- Use caution to avoid contact with sharp edges. Doors, covers, etc. may have edges that can cut or snag skin and clothes. Use caution when working on, cleaning or servicing the appliance.
- Keep hands and fingers out of the path of the loading door when closing to avoid pinching.

Strains, Over-Extension, Over-Exertion and Lifting Hazards

- Use caution when loading or unloading heavy product from the appliance. Cooked product may be heavy and result in sprains, strains or injury to back, arms, hands or legs. Do not lift more than you are safely capable of lifting.

Other Precautions

- Never stand on top of the appliance for any reason.
- Do not store anything on top of the appliance.
- The oven is not a self-cleaning appliance – do not attempt to burn off surface contamination.

Safe Operating Rules (Part 2 of 2)

YOU MUST READ AND UNDERSTAND THIS SECTION BEFORE YOU OPERATE THIS APPLIANCE.

Smoke or Fire Hazard

- If you see flames or smoke in or around the appliance:
 - Turn the appliance off and contact your supervisor or an authorized service provider.
 - Call 911 or contact fire safety personnel in accordance with your employer's emergency plan.
 - **Do not open the loading door** as this will allow oxygen to reach any flames and may cause injury to persons, property damage and may cause loss of life.
- Do not operate the appliance or any other appliance if you hear bangs, pops or other abnormal noises. Turn off the appliance and contact your supervisor or authorized service provider.
- Do not allow any flammable materials to be put into the appliance. The following materials are flammable:
 - Gasoline and petroleum products, including wax and tar.
 - Wood chips, wood and paper.
 - Flour dust and fine corn meal that can become airborne.
 - Charred baked products or any other burned material.
 - Animal and vegetable fats that vaporize or become overheated.
- Do not operate the appliance if an attached fire suppression system or fire alarm system is dysfunctional or has been discharged. Contact your supervisor or contact the fire safety system servicer.
- If a fire suppression system discharges while you are operating the appliance, turn off the appliance and follow your employer's emergency plan, or exit the building or work area.

Electrical Hazard

- Do not operate the appliance if electrical covers are removed or there are frayed, burned or exposed wires or if any live electrical terminals are exposed. Turn off the appliance and any circuit breaker or disconnect device supplying electrical power to the appliance as described in your employer's emergency plan.
- Do not operate the appliance if any circuit breaker or fuse connected to the appliance becomes tripped and cannot be reset. Contact your supervisor or authorized servicer or electrician to correct the condition before operating the appliance. Alert other employees and service personnel to the hazard.
- Do not operate the appliance if you feel an electrical shock when in contact with the appliance or other devices attached to the appliance. Contact your supervisor or authorized servicer or electrician to correct the condition before operating the appliance. Alert other employees and service personnel to the hazard.

Improper Operation

- Do not operate the appliance if covers, doors or other components are removed.
- Do not operate the appliance if any other person has applied a lock-out on the electrical supply or has tagged the appliance in a way to suggest that the appliance not be used. Contact your supervisor for further instructions or refer to your employer's safety plan.

Health and Safety in Cooked Products

- For the safety and health of those who will consume goods produced through the use of the appliance, use all caution and diligence to prevent the ingestion of any item or material that is unsafe or unfit for human consumption.
- Do not use the appliance if you see any material floating in the air in the appliance or if you see any foreign matter in the finished food product.
- Do not use the appliance if you smell unfamiliar smells or if you smell any odor that you know to be unhealthy.
- Do not under-cook any product that can carry bacteria such as but not limited to e-coli, salmonella or any other pathogen.
- Do not cook, roast or handle any meat or meat product that contains any known diseases or pathogens.
- In all cases, follow all food-safe practices as mandated by law and your employer

Control Overview (Part 1 of 2)

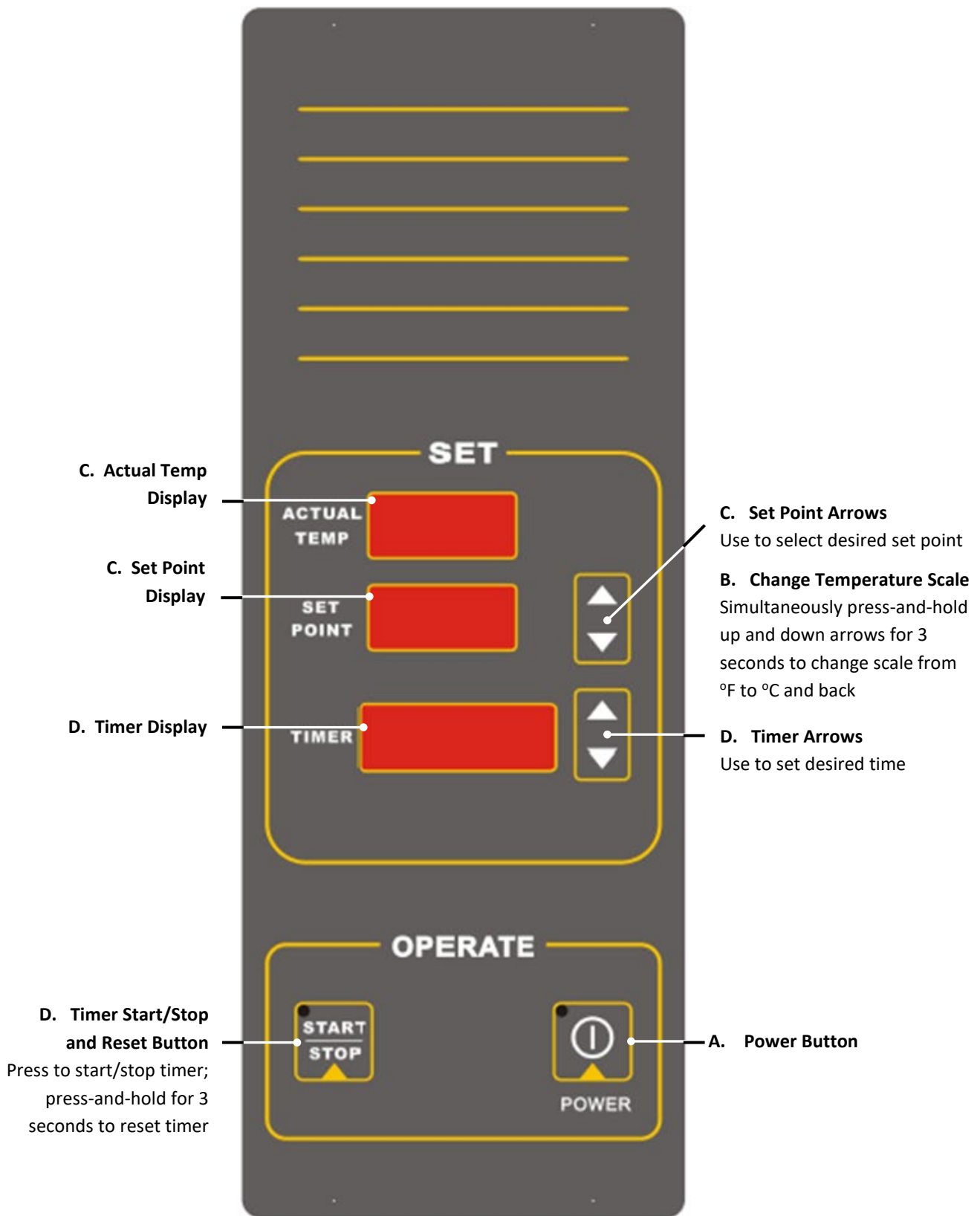











Control Overview (Part 2 of 2)

NOTICE

During the first few hours of operation, you may notice a small amount of smoke coming from the rotisserie and/or a faint odor. This is normal in a new oven and will disappear after a few hours of use.

- A Power Button.** Press this button to turn the oven on or off. The Power indicator light will remain on whenever the appliance is connected to an electrical supply.
- B Change Temperature Scale.** The oven can display temperatures in either °F or °C. To change from one scale to the other, simultaneously press-and-hold both Set Point arrows for 3 seconds. Unless selected otherwise, this scale will remain active for all future startups. Saved recipes will automatically change to the selected scale.
- C Set Point and Actual Temperature.** Use the set point arrows to enter the desired temperature, which will appear in the adjacent set point display. The oven will heat or cool to match the set point and the oven temperature will appear in the actual temp display
- D Cook Timer.** Use the set point arrows to enter the desired temperature, which will appear in the adjacent timer display. The timer start/stop and reset button can be used in the following ways:
 - 1 Start the Timer.** Press the start/stop button once to start the timer. When the timer is counting, the timer colon will flash. If the loading door is opened while the timer is counting, the countdown will automatically pause. The countdown will resume when the door is closed. A buzzer will sound when the timer has counted to zero. Press any button on the control to silence the buzzer.
 - 2 Stop the Timer.** If the timer is counting, press the start/stop button again to stop the countdown. When the timer is stopped, the entire timer display will also flash.
 - 3 Reset the Timer.** Press-and-hold the button to reset the timer.

Maintenance and Cleaning

	WARNING	DISABLE ELECTRICAL POWER AT SERVICE BREAKER BEFORE CLEANING OVEN.	
	WARNING	KEEP WATER AND SOLUTIONS OUT OF CONTROLS. NEVER SPRAY OR HOSE CONTROL CONSOLE.	
	CAUTION	ALWAYS KEEP THE AREA NEAR THE APPLIANCE FREE FROM COMBUSTIBLE MATERIALS.	
	CAUTION	KEEP THE FLOOR IN FRONT OF THE APPLIANCE CLEAN AND DRY. IF SPILLS OCCUR, CLEAN THEM IMMEDIATELY TO AVOID THE DANGER OF SLIPS OR FALLS.	
	CAUTION	MOST CLEANERS ARE HARMFUL TO THE SKIN, EYES, MUCOUS MEMBRANES AND CLOTHING. PRECAUTIONS SHOULD BE TAKEN WHEN USING THEM. WEAR RUBBER GLOVES, GOGGLES OR FACE SHIELD AND PROTECTIVE CLOTHING. CAREFULLY READ THE WARNING AND FOLLOW THE DIRECTIONS ON THE LABEL OF THE CLEANER TO BE USED.	
	NOTICE	Never use chlorine-based cleansers on this appliance. Chlorine corrodes stainless steel.	
	NOTICE	To maintain optimum safety and performance, it is recommended that a program of regular maintenance be implemented. It is the sole responsibility of the user to establish, schedule and enforce such a program. Although the actual service schedule will vary depending on the environment in which the equipment is operating, it is recommended that the above be done by an LBC-authorized service representative every six months.	

Daily

- Remove the racks and rack supports. Sink-wash these parts with warm water and soap.
- Clean the oven interior and exterior with warm water, soap and a soft cloth. Clean the control with a damp cloth only. **Do not allow water to run down the face of the control.**
- With the loading door open, hinge the inner glass frame outward for cleaning. **Do not use abrasive cleaners or wash pads as abrasives will damage the low-energy coating.**

Monthly

- Inspect the cooling fan in the front panel for lint or other build up. Clean with a dry rag as needed.
- Inspect rear motor for lint or other contaminant build up. Clean with a dry rag as needed.

As Needed

- Remove the rear fan panel (covers fan at rear interior of oven). Sink-wash this part with warm soap and water. Clean the area behind the panel with warm soap and water.

Conditions of Installation





LBC Bakery Equipment Co. shall, for a fee contingent on site location and provided that conditions of installation are met, provide a factory-authorized service agency to install the LBC Rotisserie. The job site must be ready for the installation before LBC Bakery Equipment, Inc. or its authorized agent arrives. If the installation site is not properly prepared or if there are construction delays, the customer shall be responsible for all expenses incurred during this delay. All expenses resulting from job delay or extension, for reasons beyond the control of LBC Bakery Equipment, Inc., shall be the responsibility of the customer. Installation shall be conducted during normal business hours. This installation is for a single trip. **Start-up and training are not included.**

IN ALL CASES, THE ELECTRICAL, MECHANICAL CONNECTIONS AND VENTILATION MUST MEET ALL FEDERAL, STATE AND LOCAL CODES OR ORDINANCES.

It is the responsibility of the owner/operator to do the following:

- A) Secure all required permits and meet all local code requirements.
- B) Ensure the installation site is cleared and ready for installation before the authorized installer arrives on site. The site shall be smooth and level.
- C) Provide electrical utilities within five (5) feet of the installation location per the specifications provided by LBC Bakery Equipment, Inc.
- D) Provide licensed trades person to make the final electrical connections.
- E) Provide adequate ventilation, including vented hoods and associated roof penetrations.
- F) Remove all packing materials, crates, etc. resulting from the installation.
- G) Provide any sheet metal work required by local codes or otherwise to bridge gaps between appliance and adjacent walls or other building structures.

Receiving and Unpacking

	CAUTION	THIS APPLIANCE WEIGHS UP TO 580 LBS. FOR SAFE HANDLING, INSTALLER SHOULD OBTAIN HELP AS NEEDED OR EMPLOY APPROPRIATE MATERIAL-HANDLING EQUIPMENT (SUCH AS A FORKLIFT, DOLLY OR PALLET JACK) TO REMOVE THE UNIT FROM ITS PACKING MATERIALS AND TO MOVE IT TO THE PLACE OF INSTALLATION.	
	CAUTION	SHIPPING STRAPS ARE UNDER TENSION AND CAN SNAP BACK WHEN CUT.	

Receiving

Upon receiving the appliance, immediately check for damage (visible and concealed) and loss. **Visible damage must be noted on the freight bill at the time of delivery and signed by the carrier's agent.** Concealed damage or loss means damage or loss which does not become apparent until the merchandise has been unpacked. **If concealed damage or loss is discovered upon unpacking, make a written request for inspection by the carrier's agent within 15 days of delivery.** All packing material should be kept for the inspection. **DO NOT return damaged merchandise to LBC Bakery Equipment, Inc.; file your claim with carrier.**









Location

Prior to unpacking, move the appliance as near to its intended location as practical. Existing packaging will help protect the oven from physical damage normally associated with moving it through hallways and doorways.

Unpacking

The appliance will arrive inside a wood frame and affixed to a pallet. Remove the wood frame and strapping bands before lifting the unit from the pallet and placing in its intended location.

Installation (Part 1 of 2)

	WARNING	INSTALLATION OF THIS APPLIANCE MUST BE DONE BY PERSONNEL QUALIFIED TO WORK WITH ELECTRICITY AND GAS. IMPROPER INSTALLATION CAN CAUSE INJURY TO PERSONNEL AND/OR DAMAGE TO EQUIPMENT.	
	CAUTION	ALL ELECTRICAL, MECHANICAL, GAS, VENTILATION AND EXHAUST CONNECTIONS MUST MEET ALL FEDERAL, STATE AND LOCAL CODES OR ORDINANCES.	
	CAUTION	EACH OVEN MAY WEIGH UP TO 580 LBS. FOR SAFE HANDLING, INSTALLER SHOULD OBTAIN HELP AS NEEDED OR EMPLOY APPROPRIATE MATERIAL-HANDLING EQUIPMENT SUCH AS A FORKLIFT, DOLLY OR PALLET JACK.	
	CAUTION	ANY STAND, COUNTER OR OTHER DEVICE ON WHICH THIS APPLIANCE WILL BE LOCATED MUST BE DESIGNED TO SUPPORT ITS WEIGHT	
	NOTICE	During the first few hours of operation, you may notice a small amount of smoke coming from the rotisserie and/or a faint odor. This is normal in a new oven and will disappear after a few hours of use.	

Clearances

Minimum clearance from combustible construction: 0" [0mm] from sides, 0" [0mm] from back and 12" [305mm] from top. This appliance may be installed on combustible surfaces. The installation location must allow adequate clearances for servicing and for the proper operation of the loading door.

Legs, Casters or Stand

Legs or casters are available for single and stacked appliance combinations. Additionally, a single unit may have a stand. install the appliance on legs, casters or a stand with the stainless steel hardware provided (16 ea of the following: 10-1.2 x 20mm hex bolts, 10mm split lock washer and 10mm plain washers).

Stacking

If stacking appliances, gently place the top oven on the bottom oven with the doors and sides aligned. Secure the appliances through the pre-attached stacking brackets at the underside of the rotisserie and into the threaded receiving holes at the topside of the rethermalizer. Use the stainless steel hardware provided (16 ea of the following: 10-1.2x20mm hex bolts, 10mm split lock washers and 10mm plain washers). Check both appliances to ensure they are level.

Electrical Power Connection

A mounting plate with a 1.25" [32mm] hole to connect an electrical conduit connector is installed at the bottom of the control compartment. The plate may be moved to the top of the appliance to accommodate different connection points as shown in the Specifications section of this manual. Use flexible conduit or cord if the oven is installed with casters, providing sufficient length to allow the oven to be moved for cleaning without applying tension to the electrical connections.

Installation (Part 2 of 2)

Safety Tether

Units on casters must be secured to a building structure with the safety tether provided. Affix one end of the tether to a side panel of the unit (the non-control side is recommended) using any existing panel mount screw. An additional hole must be drilled next to the existing mount screw to affix the 2-hole plate located on either end of the tether. A drill bit and mounting hardware are provided in the tether kit. Attach the loose end of the tether to a secure structure and affix the warning label provided (“WARNING – ATTENCION: RISK OF ELECTRIC SHOCK ...”) to the control-side panel.

Interim Inspection

Prior to turning oven on, verify the following:

- Loading door(s) open/close freely past 90° without obstruction
- All packing materials have been removed from inside oven
- Clear protective plastic covering data plate has been removed
- Fingerprints, tape residue, etc. have been cleaned from oven interior and exterior
- Any loose screws have been tightened; any loose power connections have been tightened

Controller Startup Check (Refer to Controller Operation section)

While oven is connected to live power, press the control panel power button and verify that the following conditions occur on initial startup:

- Oven pre-heats (elements are energized) to the temperature programmed in the open recipe
- Interior ceiling and rear wall heat-circulation fans are on
- Control compartment axial fan is on
- Values appear in the actual temp, set point and timer LED displays

Loading Door Switch Check

While the oven is preheating, open the loading door and verify the following conditions:

- The word “door” flashes in the timer
- Heat turns off (elements are de-energized)
- Interior ceiling and rear wall heat-circulation fans turn off

Interior Lights Check

While the oven is preheating, press the start/stop button and verify that both interior lights illuminate.

Set Temperature Scale

Simultaneously press-and-hold set point up and down arrows for 3 seconds to change scale from °F to °C and back.

Controller Calibration

Insert a thermocouple inside the appliance cook chamber at the center of any oblong hole in the fan cover. Route the probe wire out of the loading door opening and adjust the oven set point to 350°F (177°C). Allow the oven to reach the set point and stabilize for at least 90 minutes. If the thermocouple reading and the controller actual temperature differ by more than a couple degrees, the control must be calibrated. To begin, make a note of the temperature difference between the thermocouple and the controller actual temperature, then turn the control power button off and hold the probe button for 3 seconds until a value appears in the set point display. Use the set point up or down arrow to add or subtract the difference in temperature. (EXAMPLE: If the thermocouple is 10° higher than the actual temperature, add 10. If the thermocouple is 10° lower than the actual temperature, subtract 10.) Turn the control button on and re-check the thermocouple against the controller actual temperature. Repeat this procedure until the two temperatures match.

Parts List (Part 1 of 4)



WARNING

BOTH HIGH AND LOW VOLTAGES ARE PRESENT INSIDE OF THIS APPLIANCE WHEN THE UNIT IS PLUGGED/WIRED INTO A LIVE RECEPTACLE. BEFORE REPLACING ANY PARTS, DISCONNECT THE UNIT FROM THE ELECTRIC POWER SUPPLY.



CAUTION

USE OF ANY REPLACEMENT PARTS OTHER THAN THOSE SUPPLIED BY LBC OR THEIR AUTHORIZED DISTRIBUTORS CAN CAUSE BODILY INJURY TO THE OPERATOR AND/OR DAMAGE TO THE APPLIANCE AND WILL VOID ALL WARRANTIES.



NOTICE

Service on this or any other LBC appliance must be performed by qualified personnel. For an approved service representative in your area, visit our website at www.lcbakery.com or call our factory toll free at 1-888-722-5686.



Parts List (Part 2 of 4)

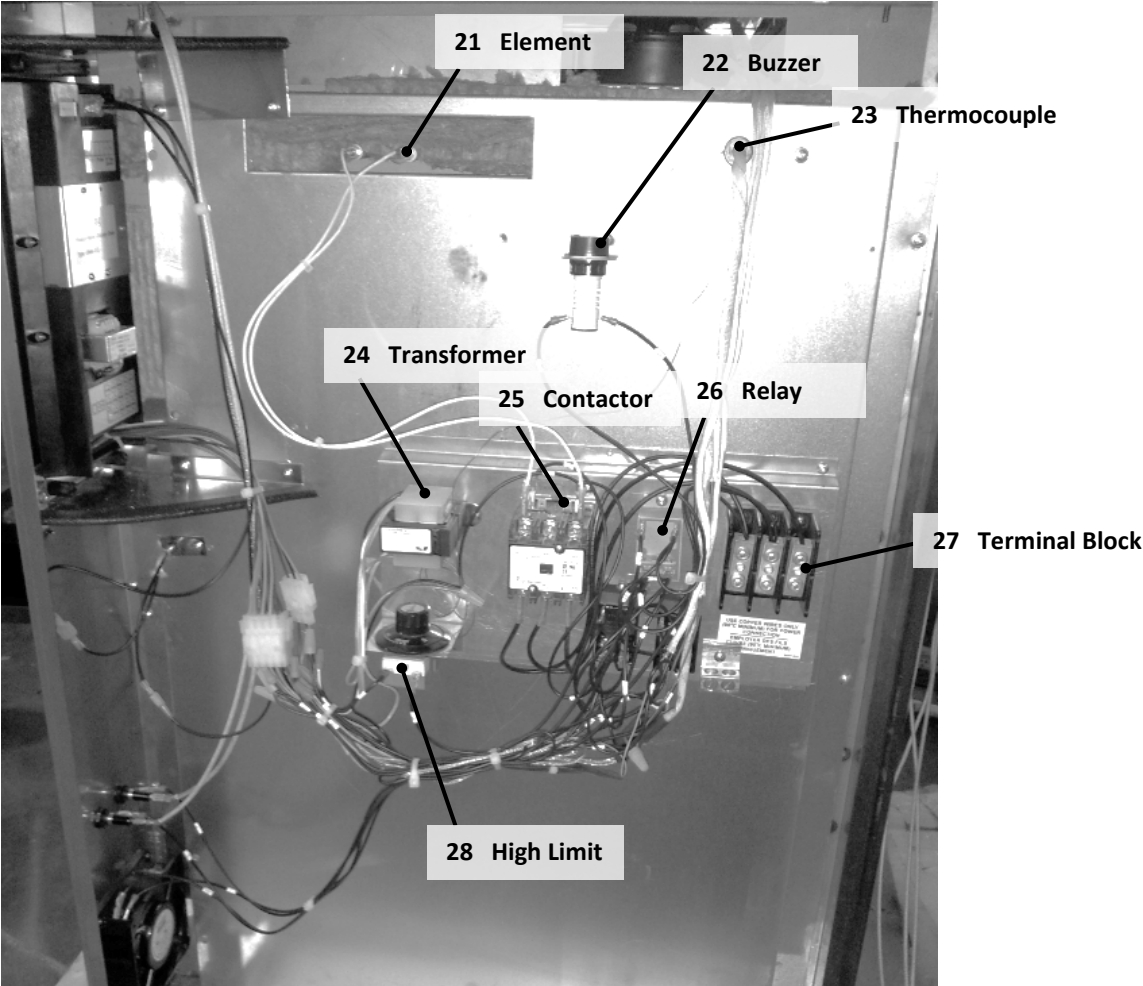

Control Compartment



Thermal Snap Disc

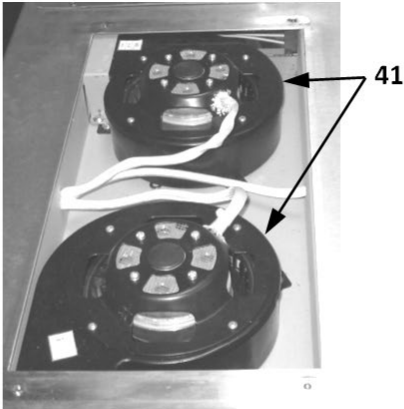

Ceiling Fans

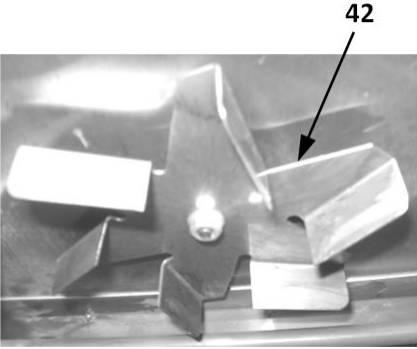

Ceiling Fan Blade

Parts List (Part 3 of 4)

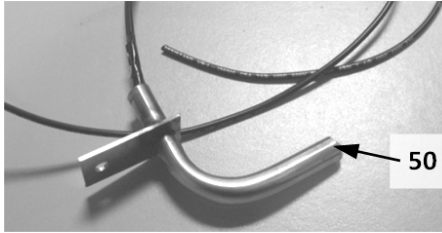

Door Switch

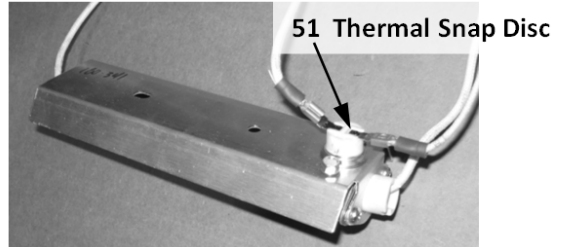

Interior Light (Reverse View)

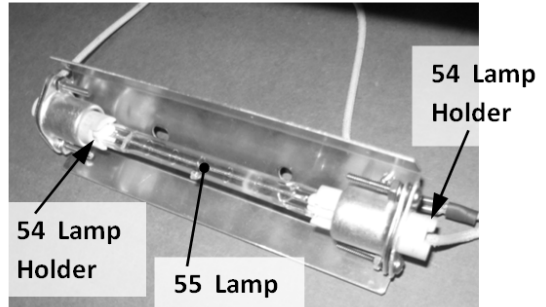

Interior Light (Front View)

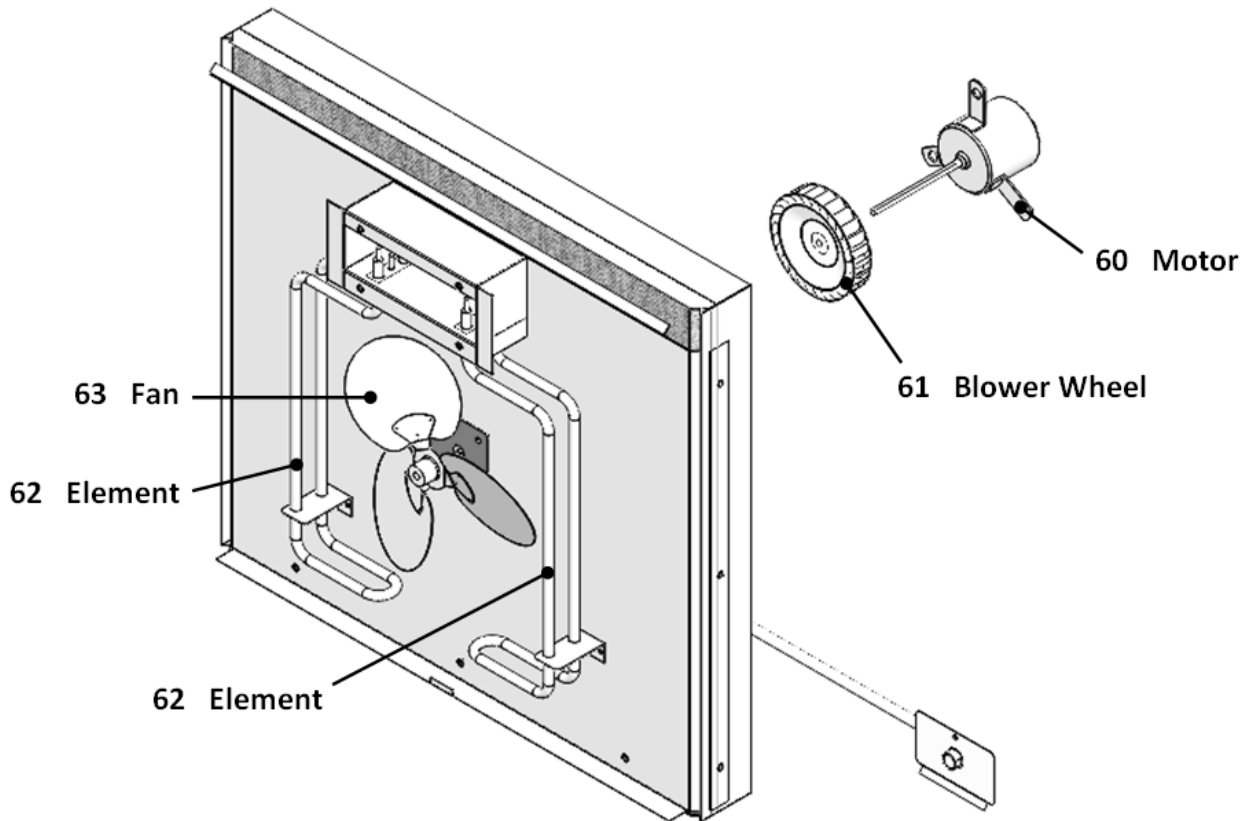

Parts List (Part 4 of 4)

Item No.	Part Description	Quantity	Part No.	Usage
1	Controller	1	40102-81	
2	15A Fuse	2	30900-01	
3	Fuse Holder	2	30901-02	
4	Axial Fan	1	71500-33	
5	Caster (Swivel with Brake)	4	72901-33	
6	Rack	5	180-812	
7	Rack Support, Left Hand	1	180-813	
	Rack Support, Right Hand	1	180-814	
8	Inner Door	1		
9	Outer Door	1		
21	Element, 2kW - Ceiling	0 or 1	11090-39	1 Phase Only
	Element, 3kW - Ceiling	0 or 1	11090-40	3 Phase Only
22	Buzzer	1	30802-07-1	
23	Thermocouple	1	41100-42	
24	Transformer	1	31400-26	
25	Contactactor	1	30700-17	
26	Relay	3	30701-05	
27	Terminal Block	1	30500-07	
28	High Limit	1	30401-33	
40	Thermal Snap Disc	1	30301-05	
41	Ceiling Fan	2	71500-32	
42	Fan Blade, Ceiling	2	180-205-1	
50	Door Switch	1	180-767-2	
51	Thermal Snap Disc	2	30301-06	
54	Lamp Holder	4	31602-21	
55	Lamp, 500W	2	31603-87	
60	Motor	1	30200-58	
61	Blower Wheel	1	71500-34	
62	Element, 3kW – Rear Wall	2	180-438	
63	Fan Blade	1	71500-11	

Optional Parts and Accessories

Item No.	Part Description	Quantity	Part No.	Usage
70	Stand with Casters	1	LST7	
71	Caster (Swivel with Brake)	4	72901-33	
72	4" Adjustable Leg	4	72901-35	
73	6" Adjustable Leg	4	72901-34	
74	Restraint Kit (Safety Tether)	1	72609-51	

Wiring Diagram (Part 1 of 2)

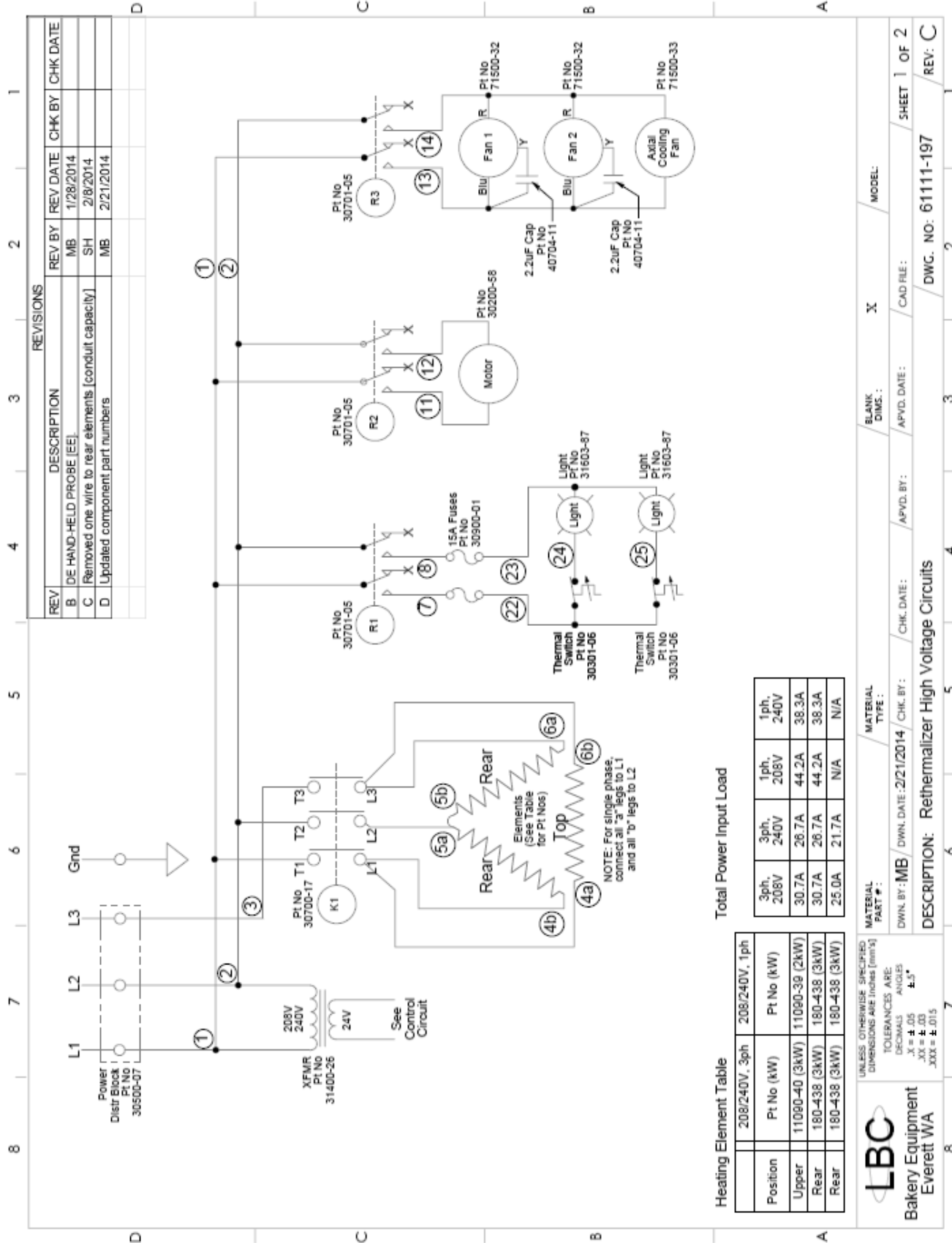



LIMITED WARRANTY

LBC Bakery Equipment ("LBC Equipment") has been skillfully manufactured, carefully inspected and packaged to meet rigid standards of excellence. LBC Bakery Equipment, Inc. (LBC) warrants products produced and sold by LBC and its duly authorized agents against defects in materials and workmanship within the following limitations:

What is Provided:

- Limited replacement parts as specified below, including standard ground shipping from LBC or service parts center when required.
- Limited labor for repair as specified below, including authorized service agent's transportation, portal to portal, up to one hundred (100) miles round trip and two (2) hours travel time.
- LBC, or an authorized service representative, will repair or replace, at LBC's sole discretion, any LBC equipment, including but not limited to the listed exclusions.

Coverage Period:

Extending from the date of shipment from LBC or its duly authorized dealer/distributor for the specified period:

- LRO and LMO Model Rack Ovens, LRP Model Rack Proofers, LRPR Model Retarder Proofers, LCR Model Rotisseries and LHC Model Holding Cabinets for a period of one (1) year limited parts and labor.
- Replacement parts shall be warranted for a period of ninety (90) days after installation by an authorized LBC service agent.

Conditions:

- Covered equipment must have been properly installed according to the requirements of the installation manual and all applicable local codes.
- The equipment shall not have been abused, misused or neglected or used for purposes other than intended by LBC.
- Water connected to the appliance shall have been in compliance with the following requirements:
 - Cold Water: 30 - 80 PSI
 - pH: 7 - 7.5
 - Conductivity: < 1/500,000 Ω per inch
 - Total Dissolved Solids: < 100 ppm
 - Hardness: 6.3 - 8.8 grains per gallon
 - Maximum Salinity and Ion content:
 - Chlorides: < 30 ppm
 - Sulfates: < 40 ppm
 - Iron: < 0.1 ppm
 - Copper: < 0.05 ppm
 - Manganese: < 0.05 ppm
- It is the responsibility of the purchaser to install and maintain the water supply to the appliance. Failure to provide satisfactory water quality in accordance with the operating manual requirements can cause damage to internal components and will VOID the warranty.
- All repair work is to be performed by an LBC authorized service agent.
- Equipment must be at the installation location of the original purchaser/user and shall not have been resold or reclaimed by another party.

Conditions (Continued):

- LBC equipment is for commercial use only. If sold as a component of another (OEM) manufacturer's equipment, or if used as a consumer product, such equipment is sold AS IS and without any warranty.
- Conditions of sale of the equipment shall have been met in full.
- The request for repair shall be made within the limited period of the warranty.
Failure to meet the above conditions will void this warranty.

Exclusions:

This warranty does not cover the following:

- Routine general maintenance, or periodic adjustment.
- Thermostat calibration after the first 30 days of use.
- Glass, Lamps, Gaskets, Oven Racks and other consumable parts.
- Air and gas burner adjustments.
- Fuse replacement.
- Cleaning and adjusting burners and pilot burners.
- Rack oven shutter adjustments.
- Repairs adjustments and corrections in the refrigeration portion of retarder/proofers resulting from the improper installation.
- Retightening of screws and fasteners.
- Failures caused by erratic or inadequate electrical, water, ventilation or gas service.
- Unauthorized repairs.
- Premature rusting, corrosion, or mineral build up caused by incoming water.
- Attached water treatment systems.
- Expedited freight on replacement parts other than standard ground shipments.
- Ordinary wear and tear.
- Use of the equipment for purposes other than those intended including non-commercial use such as residential or domestic.
- Appliances installed outside the contiguous U.S., including Alaska and Hawaii, and Canada.
- Incidental costs, charges, loss of business and damages as incurred by the user or others as a result of the use or failure of the equipment.
- Work and workmanship of the authorized service agent or others in the repair of the equipment.
- Other failures that are beyond the reasonable scope of this warranty.
- Damage caused during shipment is to be reported to the carrier, is not covered under this warranty, and is the sole responsibility of the purchaser/user.
- Natural disaster.

This warranty is exclusive and in lieu of all other warranties, expressed or implied, including expressed or implied warranties of merchantability or fitness for a particular purpose, each of which is hereby expressly disclaimed. The remedies described herein are exclusive and in no event shall LBC be liable for special, consequential or incidental damages for the breach or delay in the performance of this warranty